

Ultra SuperServer SYS-620U-TNR



Key Applications

- Virtualization
- HPC
- Cloud Computing
- High End Enterprise Server
- Software Defined Storage
- Application Tier Service Provider
- 5G/Telco

Key Features

- Dual Socket P+ (LGA-4189) 3rd Gen Intel® Xeon® Scalable Processors;
- Intel® C621A Chipset;
- 32 DIMM Slots; Up to 8TB DRAM; Up to 8TB Intel® Optane™ Persistent Memory (up to 12TB with DRAM); 3200/2933/2666 ECC DDR4 LRDIMM; RDIMM; Intel® Optane™ Persistent Memory 200 series;
- Flexible networking options;
- 12x 3.5" hot-swap hybrid NVMe/SATA/SAS drive bays;
- 4 heavy duty fans with optimal fan speed control;
- 1200W redundant Titanium level power supplies;

[More details here](#)



Form Factor	2U Rackmount Enclosure: 437 x 89 x 737.9mm (17.2" x 3.5" x 29.05") Package: 605 x 256 x 947mm (23.81" x 10.07" x 37.28")
Processor	3rd Gen Intel® Xeon® Scalable processors Dual Socket LGA-4189 (Socket P+) supported TDP up to 270W; 3 UPI
Drive Bays	12x 3.5" hot-swap NVMe/SATA/SAS drive bays; 12x 2.5" NVMe hybrid; Optional RAID support via RAID controller AOC
Expansion Slots	Slot 1: PCI-E 4.0 x16 FH, 10.5"L Slot 2: PCI-E 4.0 x8 FH, 10.5"L Slot 3: PCI-E 4.0 x8 Internal LP Slot 4: PCI-E 4.0 x16 LP Slot 5: PCI-E 4.0 x8 FH, 10.5"L Slot 6: PCI-E 4.0 x8 FH, 10.5"L Slot 7: PCI-E 4.0 x8 FH, 10.5"L Slot 8: PCI-E 4.0 x8 FH, 10.5"L Note: Optional RSC-W2-66G4 enables PCI-E x16 in slots 5, 7. Slots 6,8 will be disabled.
On-Board Devices	SATA: SATA3 (6Gbps) via Intel® PCH 621A; RAID 0/1/5/10 support NVMe: NVMe (16GT/s); RAID 0/1/5/10 support Chipset: Intel® C621A Network Connectivity: 2x 10GbE BaseT with Intel® X710-AT2 (optional) OR 2x 10GbE BaseT and 2x 10GbE SFP+ with Intel® X710-TM4 (optional) No NIC option supported IPMI: Support for Intelligent Platform Management Interface v.2.0 IPMI 2.0 with virtual media over LAN and KVM-over-LAN support
Input / Output	LAN: 1 RJ45 Dedicated BMC LAN port USB: 2 USB 3.0 port(s) (2 rear) Video: 1 VGA port(s) Serial Port: 1 COM Port(s) (1 rear) DOM: 2 SuperDOM (Disk on Module) port

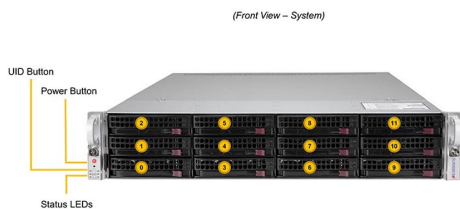

Slot	Description
1 – 2	3.5" Hot-swap NVMe/SAS3*/SATA3 Drive Bays (NVMe from CPU1)**
3 – 6	3.5" Hot-swap NVMe/SAS3*/SATA3 Drive Bays (NVMe from CPU2)**

*SAS3 support requires additional parts in optional parts list
 **NVMe support requires additional parts in optional parts list

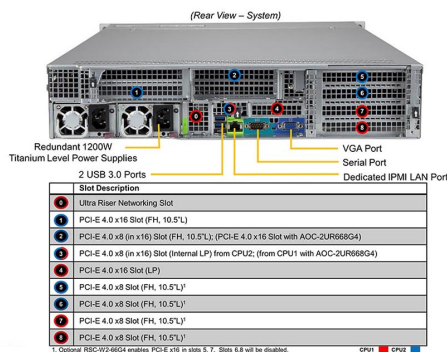

Slot	Description
1	Ultra Riser Networking Slot
2	PCI-E 4.0 x16 Slot (FH, 10.5" L)
3	PCI-E 4.0 x8 (in x16) Slot (FH, 10.5" L); (PCI-E 4.0 x16 Slot with AOC-2UR668G4)
4	PCI-E 4.0 x8 (in x16) Slot (Internal LP) from CPU2; (from CPU1 with AOC-2UR668G4)
5	PCI-E 4.0 x16 Slot (LP)
6	PCI-E 4.0 x8 Slot (FH, 10.5" L) ¹
7	PCI-E 4.0 x8 Slot (FH, 10.5" L) ¹
8	PCI-E 4.0 x8 Slot (FH, 10.5" L) ¹
9	PCI-E 4.0 x8 Slot (FH, 10.5" L) ¹

1. Optional RBC-W2-6604 enables PCIe x16 in slots 5, 7. Slots 6,8 will be disabled.

Cooling System	4x 8cm heavy duty fan(s)
Power Supply	1200W Redundant Power Supplies with PMBus Dimension (W x H x L): 73.5 x 40 x 203 mm Output Type: AC-Input
System BIOS	BIOS Type: AMI 32MB SPI Flash EEPROM
Management	SuperDoctor® 5; Watch Dog; NMI; SUM; KVM with dedicated LAN; Intel® Node Manager; IPMI 2.0; Redfish API; Supermicro Out of Band (OOB) License (Included with Server)
PC Health Monitoring	CPU: Monitors for CPU Cores, Chipset Voltages, Memory 7 +1 Phase-switching voltage regulator FAN: Fans with tachometer monitoring Status monitor for speed control Pulse Width Modulated (PWM) fan connectors Temperature: Monitoring for CPU and chassis environment Thermal Control for fan connectors
Dimensions and Weight	Height: 3.5" (89 mm) Width: 17.2" (437 mm) Depth: 29.05" (737.9 mm) Gross Weight: 57.5 lbs (26.2 kg) Net Weight: 35.5 lbs (16.2 kg) Packaging: 10.07" (H) x 23.81" (W) x 37.28" (D) Available Color: Black Front & Silver Body
Operating Environment	Operating Temperature: 10°C ~ 35°C (50°F ~ 95°F) Non-operating Temperature: -40°C to 60°C (-40°F to 140°F) Operating Relative Humidity: 8% to 90% (non-condensing) Non-operating Relative Humidity: 5% to 95% (non-condensing)
Motherboard	Super X12DPU-6
Chassis	CSE-829U3TS-R1K22P-T