

SEN-9648P-24V-SS

Managed 8 x 10/100/1000 PoE+ & 4 x GbE SFP
Switch, Substation Approval, Aluminum

Description

Volktek's SEN-9648P-24V-SS Managed Industrial switch is equipped with 8 port 10/100/1000BASE-T and 4 Gigabit SFP slots that are PoE+ compliant. Engineered with hardened components and enclosed in a rugged case, the switch can operate in wide temperatures from -40°C to 75°C and excellent tolerance capability to high vibration and shock. As an Industrial switch, the SEN-9648P-24V-SS suits your heavy industrial environments and yet contains all the standard features of other switches.

PoE+ function on 8 ports 10/100/1000BASE-T complies with IEEE 802.3at standards and allows to supply up to 30W per port for network attached devices such as Wi-Fi Access Points, VoIP phones and IP surveillance cameras that can be powered by Ethernet connectivity. The SEN-9648P-24V-SS eliminates the need for installing additional power outlets or adapters, thus network power planning is simplified and overall installation and maintenance costs are reduced. In addition, the Layer 2 switch offers a full complement of management functions to allow easy-to-use configuration and monitoring.

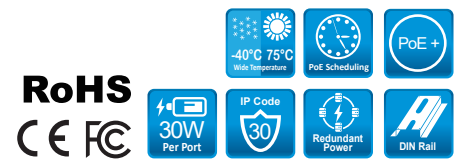

Features Highlight

Robust Switch Performance

SEN-9648P-24V-SS is built with IP30 aluminum case protection, surge and ESD protection to deliver robust performance and withstand extreme conditions in Industrial environments. The SFP ports support 1000Mbps for high bandwidth transmissions and the SFP DDM feature enables service providers to monitor SFP parameters. In case of any abnormal hardware condition, the switch automatically sends warnings through email and relay output with real-time alarm messages. This assists the system administrators to immediately react to emergency events and diagnose the faults more efficiently for smoother network operations.



High-Power Budget for PoE Network Devices

To reduce the required time and cost of installing additional electrical sources, the SEN-9648P-24V-SS implements PoE+ technology. The switch supplies power over the same cable that is used to carry network traffic and delivers a high power budget of 240W to suit various power requirements. Using SNMP and Web interface, the PoE+ functions on each port can be enabled and disabled to save power and energy.

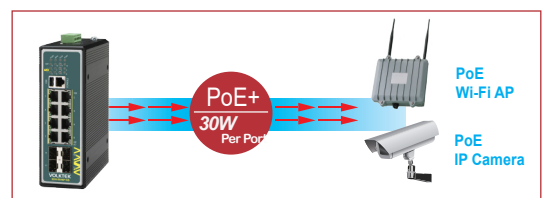

Intelligent PoE+ for powered devices

The SEN-9648P-24V-SS is designed with intelligent PoE+ features to utilize power more efficiently. To monitor real-time status of Powered Devices (PDs), the switch sends alive-checking packets to PDs. This reduces management burden and increases system reliability. Using power scheduling mechanism of the switch, administrators can set power on each port to a desired hourly/weekly schedule and can enable or disable the power output to these devices accordingly.



Redundant Power system

Mission-critical industrial applications need to operate without any interruptions because even a minimum network downtime can hugely impact the overall output. Providing continuous power as well as data to such applications is now made easy with SEN-9648P-24V-SS redundant power system. The switch is designed with standard industrial terminal block for redundant power. In case the primary power supply fails, the secondary power will enable the switch to provide continuous service.



Features Highlight

Efficient network monitoring and proactive capability

In a network, the issues that impact network performance can be quickly resolved with the SEN-9648P-24V-SS' most accepted and enhanced traffic management, monitoring and analysis protocols such as SNMP and RMON. SNMP allows end users to centrally manage different levels in a network and RMON gives the capability to monitor the network performance. Service providers can ensure a reliable network by identifying connectivity and performance issues and isolating the problem remotely on individual switches. This avoids high OPEX and provides administrators the control they need to manage a healthy and efficient network.

Bandwidth management to prevent unpredictable network status

Industrial surveillance applications need different levels of services delivered to them reliably without any transmission delays and interruptions. The SEN-9648P-24V-SS has comprehensive QoS mechanisms which assign priority to applications and sends only specific dedicated traffic to them. In addition, bandwidth management function of the switch allocates high bandwidths to mission-critical communications and reduce the bandwidth to applications that are less critical. With full control of limiting the bandwidth, the administrators can prevent unpredictable errors and utilize the bandwidth more effectively.

Redundant Ring and Fast Recovery for Surveillance System

Even few seconds of missed communications due to link failures, especially in IP surveillance systems, can cause inconvenience and recovering it becomes very critical. Featuring with Xpress Ring, SEN-9648P-24V-SS can rapidly react to such link failures and recovers it within less than 10ms, a much faster fail-over time to support nonstop transmissions. And to handle the heavy traffic load of video and data, the switch implements.

Applications

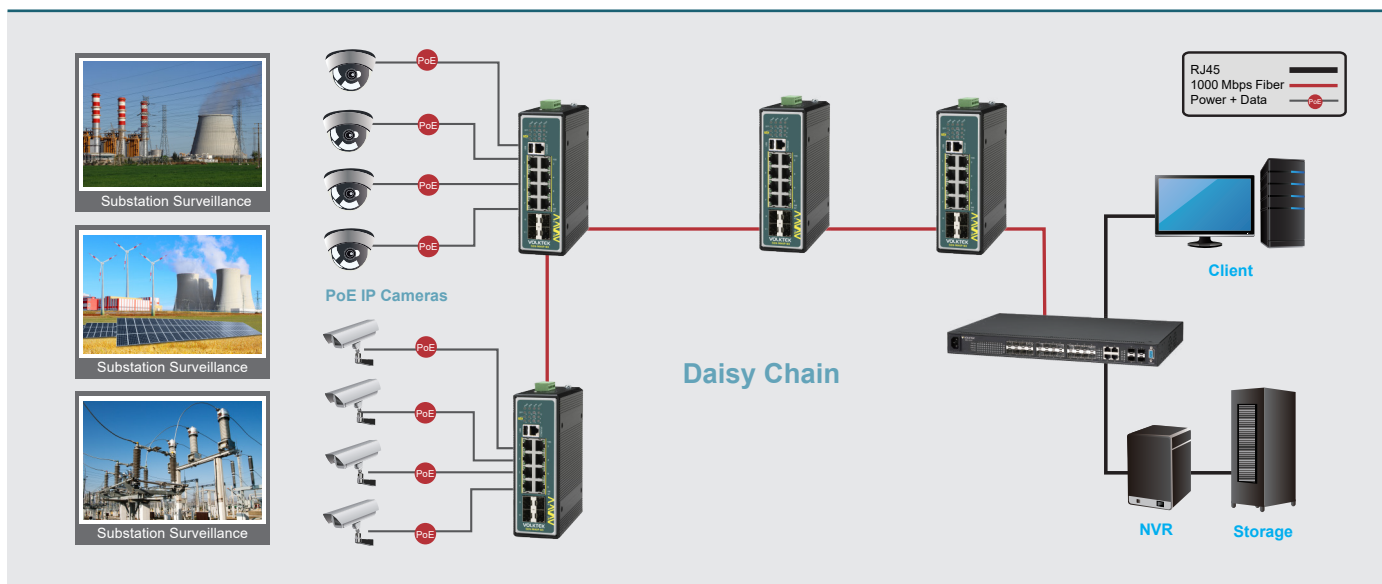

Redundant Ring

It incorporates, advanced Redundant Ring technologies, into customer's industrial automation and surveillance network to enhance system reliability and uptime in harsh factory environments.

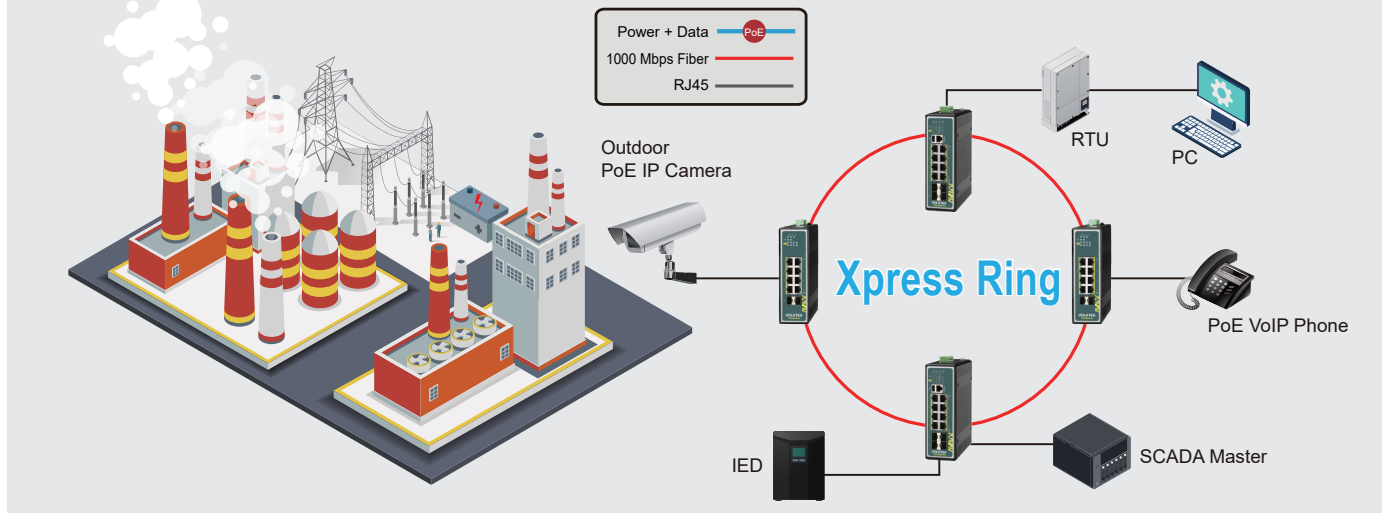

Specifications

Standards	
IEEE 802.3	10BASE-T
IEEE 802.3u	100BASE-TX
IEEE 802.3ab	1000BASE-T
IEEE 802.3z	1000BASE-SX/LX
IEEE 802.3x	Flow Control
IEEE 802.3ad	Link Aggregation
IEEE 802.1ab	LLDP
IEEE 802.1D	STP
IEEE 802.1w	RSTP
IEEE 802.1s	MSTP
IEEE 1588v2	PTP
IEEE 802.1p	Class of Service
IEEE 802.1Q	VLAN Tagging
IEEE 802.1X	Port Authentication
IEEE 802.3af	Power over Ethernet
IEEE 802.3at	Power over Ethernet Plus
IEEE 802.3az	Energy Efficient Ethernet (EEE)
Interface	
Ports	8 x 10/100/1000BASE-T (PoE RJ45)
	4 x Gigabit SFP Slots
	1 x RJ-45 Console Port
	1 x USB Port
DIP Switch	Primary/Redundant Power Voltage Drop Alarm setting
LED Panel	PWR, RPS, ALM, POST, PoE, 1000, 10/100
Features	
Performance	Jumbo frame Size: 10KBytes
	MAC Table Entries: 16K
	Active VLAN: 4K
	Switch Fabric: 24Gbps
	L2 Forwarding Rate: 17.9Mpps
Management	CLI, Telnet/SSH, HTTP/HTTPS, SNMP v1/v2c/v3, SNMP Trap, MVLAN, Firmware Upgradable, Configuration Backup/Restore, Syslog, SNMP, LLDP, UDLD, DHCP Client, DHCP Option 82, e-mail Alarm, Service Control, DDM
	STP/RSTP/MSTP, Xpress Ring, ERPS v1/v2, Dual Homing, LACP, Code Redundancy
	IEEE 802.1Q, GARP/GVRP, Port-based VLAN, MAC-based VLAN, IP-based VLAN, Protocol-based VLAN, QinQ
	IGMP snooping/Throttling/Proxy, MVR, QoS, Flow Control, Abnormal Traffic Detection, Rate Limit, Storm Control, Port Isolation, Loop Detection
VLAN	
Traffic Control	

Security	ACL, SSH, Port Security, Port-based 802.1x, MAC-based 802.1x, TACACS+, MAC limit, MAC Search, Refusal MAC, Static MAC, DHCP Snooping, DHCP Sever Screening, ARP Inspection, BPDU Guard/Filter, Root Guard, Management Host
PoE/PoE+	Scheduling, PD Alive Check, PoE Power On/OFF, Feeding Power Budget Control
Power	
Input Voltage	Primary inputs : 24~57V DC Redundant inputs : 24~57V DC
Power Consumption	System : 18W PoE Power Budget : 240W@48V or 124W@24V
Alarm Relay	One relay output, 1 A @ 24V DC
Mechanical and Environment	
Housing	Aluminum (IP30 Protection)
Mounting	DIN-Rail
Operating Temperature	-40°C~75°C
Storage Temperature	-40°C~85°C
Operating Humidity	5 to 95% RH (non-condensing)
Storage Humidity	5 to 95% RH (non-condensing)
Weight	955g
Dimension (WxHxD)	50x160x120mm (1.97x6.3x4.72inch)
Certifications	
EMI	FCC Part 15 Subpart B Class A, EN 55022 : class A EN 55011 : 2009 class A, EN 61000-6-4
EMS	EN 55024, EN 61000-6-2, EN 61000-4-2 (ESD) EN 61000-4-3 (RS), EN 61000-4-4 (Burst) EN 61000-4-5 (Surge), EN 61000-4-6 (CS) EN 61000-4-8 (PFMF)
Shock	IEC 60068-2-27
Freefall	IEC 60068-2-32
Vibration	IEC 60068-2-6
Power Substation	IEEE1613 IEC61850-3
Optional Accessories	
Power Supply	SDR-480P-48: 480W DIN-Rail 48V DC Industrial Power Supply, -25°C~70°C
GBM-104	1000BASE-SX 1.25G, Multi-mode SFP, 500m

Note :

* The SFP communication distance upon the request.

* Industrial SFP with wide operating temperature from -40°C~85°C is available upon request.

* Specifications subject to change without notice.

Dimension

