

INS-8528

Managed 8 x 10/100 RJ45 & 2 x FX/GbE SFP Industrial Switch

Description

The INS-8528 is a Managed Industrial Switch specifically designed to suit your heavy industrial environments and contains all the standard features to deploy in automation systems. Engineered with hardened components and enclosed in a rugged IP30 aluminum case, the INS-8528 can operate in wide temperatures from -40°C to 75°C and also has excellent tolerance capability to high vibration and shock.

Despite the fact that the INS-8528 is perfectly designed to operate in extreme industrial conditions; the switch is also equipped with a variety of management functions that let you configure communication parameters as you desire and monitor the network behavior in number of different simple ways. In addition, the switch is built with dual redundant power inputs to ensure reliability and maximize network up time. Other integrated features of the switch such as Auto-negotiation, Rate limitation and Port Isolation optimizes your network performance and provide a secure network, offering a cost-effective solution in a small but powerful package.



Features Highlight

Robust Switch Performance

INS-8528 is built with IP30 aluminum case protection, surge and ESD protection to deliver robust performance and withstand extreme conditions in Industrial environments. The SFP ports support 1000Mbps for high bandwidth transmissions and the SFP DDM feature enables service providers to monitor SFP parameters. In case of any abnormal hardware condition, the switch automatically sends warnings through email and relay output with real-time alarm messages. This assists the system administrators to immediately react to emergency events and diagnose the faults more efficiently for smoother network operations.



Port-BASEd VLAN, IEEE 802.1Q VLAN, GARP and GVRP to ease network planning

Planning, designing and managing complex networks is now simplified with INS-8528. The switch supports VLANs which segment large networks into smaller parts and organize them into separate broadcast domains. This helps the administrators to control the traffic patterns, limit broadcast traffic and reduce broadcast storms. As the network expands, to provide control of increased VLANs, the switch offers GVRP feature, an application protocol of GARP, which registers devices and its ports depending on their availability. This feature prevents unnecessary network traffic transmitted by unregistered users and simplifies the network design irrespective of its size.

Code Redundancy

The configuration file of the switch may be lost due to various reasons such as upgrading to a new firmware or power fluctuations and can lead to network down situation. To avoid such situations, the INS-8528 provides a perfect alternate solution using its code redundancy feature with its dual flash. The dual flash memory allows the switch to store a backup file of primary configuration on one flash space. Even if the primary configuration file is lost, the backup file will enable the switch and ensure that your network is running continuously.

Redundant Power system

Mission-critical industrial applications need to operate without any interruptions because even a minimum network downtime can hugely impact the overall output. Providing continuous power as well as data to such applications is now made easy with INS-8528's redundant power system. The switch is designed with standard industrial terminal block for redundant power. In case the primary power supply fails, the secondary power source will enable the switch to provide continuous service.



Features Highlight

Efficient network monitoring and proactive capability

In a network, the issues that impact network performance can be quickly resolved with the INS-8528's most accepted and enhanced traffic management, monitoring and analysis protocols such as SNMP and SFP DDMI (Digital Diagnostics Monitoring Interface). SNMP allows to centrally manage different levels in a network and SFP DDMI enabled on the switch, administrators can easily monitor and troubleshoot SFP parameters such as temperature, voltage, laser bias current and evaluate SFP's working condition. User can ensure a reliable network by identifying connectivity and performance issues and isolating the problem remotely on individual switches.

Comprehensive QoS Mechanisms to Assign Priority

Industrial applications need different levels of services delivered to them reliably without any transmission delays and interruptions. The INS-8528 has comprehensive QoS mechanisms which assign priority to applications and sends only specific dedicated traffic to them. In addition, bandwidth management function of the switch allocates high bandwidths to mission-critical communications and reduce the bandwidth to applications that are less critical. With full control of limiting the bandwidth, the administrators can prevent unpredictable errors and utilize the bandwidth more effectively.

Proprietary Technology Delivers Redundant Ring and Fast Recovery

Even a few seconds of missed communications due to link failures can cause inconvenience, and recovery can become critical. Volktek's proprietary Xpress Ring in INS-8528 rapidly reacts to such link failures and recovers in less than 10ms, a much faster fail-over time to support nonstop transmissions. This is critical for networks handling heavy video and data traffic. In addition, ERPS, Dual Homing, LACP and RSTP provide a highly reliable network with redundancy connections whenever required and guarantee continuous network uptime.

Applications

The INS-8528 is compatible with 10/100/1000 Mbps through RJ45 transceivers to guarantee a strong & stable connection of Ethernet, Fast Ethernet or Gigabit Ethernet, providing flexible deployment options to satisfy industrial networking requirements

The INS-8528 is built with relay contact outputs that trigger alarms to notify network engineers in the event of any malfunction of ports status or power failure, and enables them to quickly respond and resolve high priority issues.

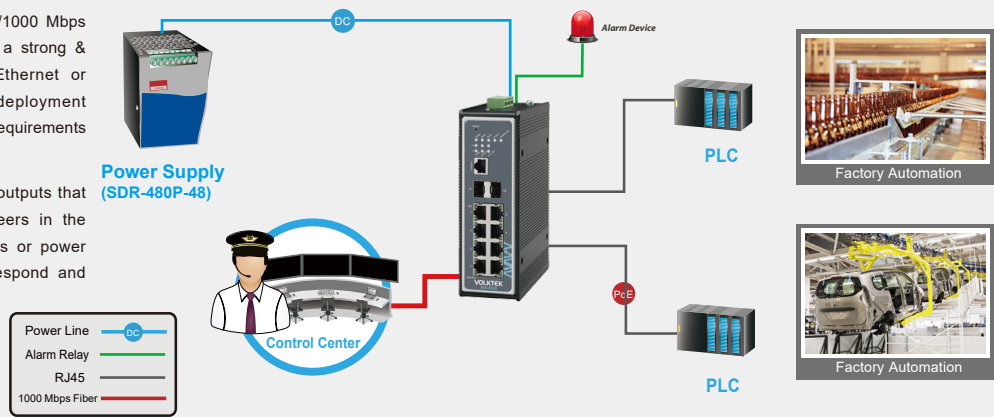

Redundant Ring

It incorporates, advanced Redundant Ring technologies, into customer's industrial automation network to enhance system reliability and uptime in harsh factory environments.

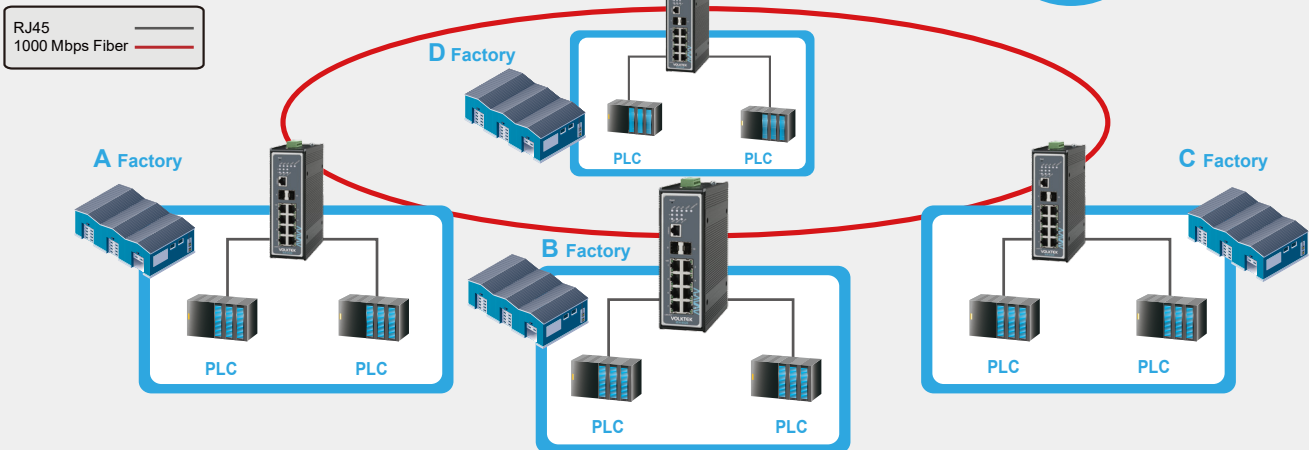

Specifications

Standards	
IEEE 802.3	10BASE-T
IEEE 802.3u	100BASE-TX
IEEE 802.3ab	1000BASE-T
IEEE 802.3x	Flow Control
IEEE 802.3ad	Link Aggregation
IEEE 802.1ab	LLDP
IEEE 802.1D	STP
IEEE 802.1w	RSTP
IEEE 802.1s	MSTP
IEEE 802.1p	Class of Service
IEEE 802.1Q	VLAN Tagging
IEEE 802.1X	Port Authentication
Interface	
Ports	8 x 10/100BASE-TX (RJ45) 2 x 100FX/GbE SFP Slots 1 x RJ45 Console Port
DIP Switch	Primary/Redundant Power Voltage Drop Alarm setting
LED Panel	PWR, RPS, ALM, POST, 1000, 10/100
Features	
Performance	Jumbo frame Size: 10KBytes MAC Table Entries: 16K Active VLAN: 4K Switch Fabric: 5.6Gbps L2 Forwarding Rate: 4.1Mpps
Management	CLI, Telnet/SSH, HTTP/HTTPs, SNMP v1/v2c/v3, SNMP Trap, MVLAN, Firmware Upgradable, Configuration Backup/Restore, Syslog, SNTP, PTP, LLDP, UDLD, DHCP Client/Relay/Option82, e-mail Alarm, Server Control, Mirroring, DDM, SFP Info, Auto-Provisioning, RMON Statistics, ModbusTCP
Reliability	STP/RSTP/MSTP, Xpress Ring, ERPS v1/v2, Dual Homing, LACP, Static Trunk, Code Redundancy
VLAN	IEEE 802.1Q, GARP/GVRP, Port-based VLAN, MAC-based VLAN, IP-based VLAN, Protocol-based VLAN, QinQ
Traffic Control	IGMP Snooping/Throttling, IGMP Proxy/Filter, MLD, MVR, QoS, Flow Control, Rate Limit, Storm Control, Traffic Monitor, Port Isolation, Loop Detection, Static Route
Security	ACL, SSH, HTTPs, SNMPv3, Port-based 802.1x, TACACS+, Port Security, MAC Search, Refusal MAC, Sticky MAC, Static MAC, DHCP Snooping, DHCP Sever Screening, ARP Inspection, BPDU Guard/Filter, Root Guard, Managed Host
Power	
Input Voltage	Primary inputs : 12~60VDC Redundant inputs : 12~60VDC
Power Consumption	System : 12W
Alarm Relay	One relay output, 1 A @ 24V DC
Mechanical and Environment	
Housing	Aluminum (IP30 Protection)
Mounting	DIN-Rail
Operating Temperature	-40°C~75°C
Storage Temperature	-40°C~85°C
Operating Humidity	5 to 95% RH (non-condensing)
Storage Humidity	5 to 95% RH (non-condensing)
Weight	850g
Dimension (WxHxD)	50x161.5x119.9mm (1.97x6.36x4.72 inch)
Certifications	
EMI	FCC Part 15 Subpart B Class A EN 55022 : class A EN 55011 : 2009 class A EN 61000-6-4
EMS	EN 55024 EN 61000-6-2 EN 61000-4-2 (ESD) EN 61000-4-3 (RS) EN 61000-4-4 (Burst) EN 61000-4-5 (Surge) EN 61000-4-6 (CS) EN 61000-4-8 (PFMF)
Shock	IEC 60068-2-27
Freefall	IEC 60068-2-32
Vibration	IEC 60068-2-6
Ordering Information	
INS-8528	Managed 8 x 10/100/1000 RJ45 & 2 x FX/GbE SFP Switch, -40°C ~ 75°C
Optional Accessories	
Power Supply	SDR-120-48: 120W DIN-Rail 48VDC Industrial Power Supply, -25°C~70°C
GBM-104	1000BASE-SX 1.25G, Multi-mode SFP, 500m
GBM-123TS	1000BASE-LX, Bi-Di SFP TX:1310/RX:1550 Single Mode, 10Km, 0°C~70°C / -32°F~158°F
GBM-123RS	1000BASE-LX, Bi-Di SFP TX:1550/RX:1310 Single Mode, 10Km, 0°C~70°C / -32°F~158°F

Note :

* The SFP communication distance upon the request.

* Industrial SFP with wide operating temperature from -40°C~85°C is available upon request.

* Specifications subject to change without notice.

Dimension

