

SD631-Q170

Desktop

Q170

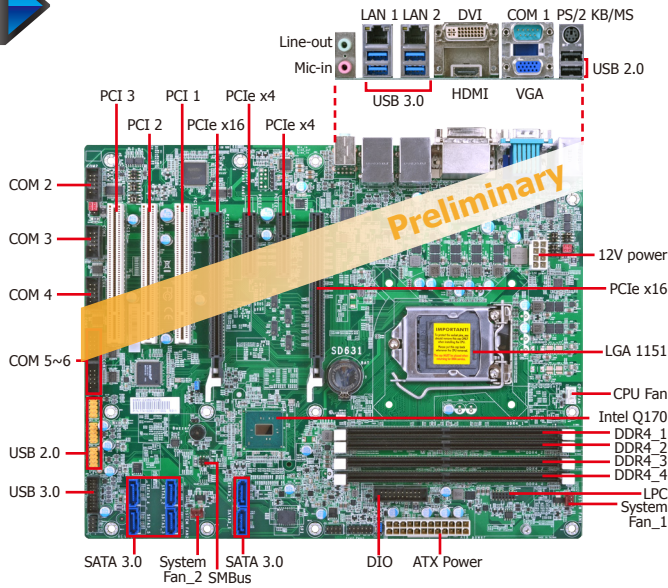

Features

- 4 DDR4 DIMM up to 64GB
- Three independent displays: VGA + DVI + HDMI
- HDMI resolution up to 4096x2160 @ 24Hz
- Multiple expansion: 2 PCIe x16 (1 x16 or 2 x8 signal), 2 PCIe x4, 3 PCI, 1 LPC
- Rich I/O: 2 Intel GbE, 6 COM, 6 USB 3.0, 8 USB 2.0
- LPC EXT-RS232/485 module extends additional 4 COM ports



2 Extension Modules for Additional 4 COM Ports (via the LPC connector)

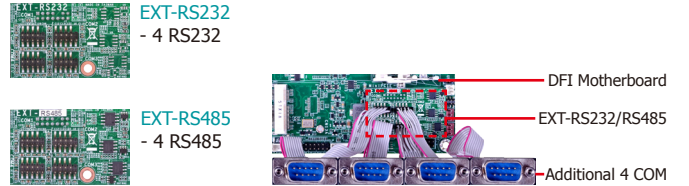

Mechanical Drawing



Block Diagram

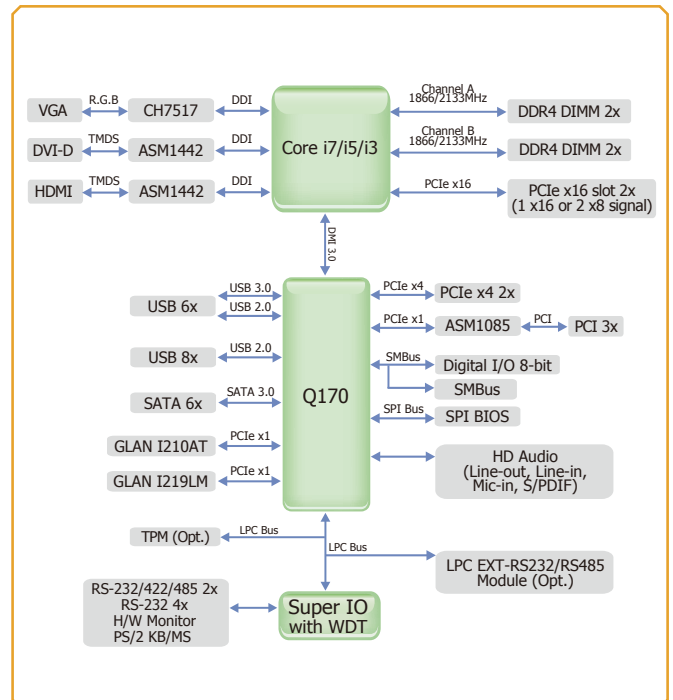

Specifications

SYSTEM	Processor	6th Generation Intel® Core™ Processors, LGA 1151 Socket Intel® Core™ i7-6700 Processor, Quad Core, 8M Cache, 3.4GHz (4.0GHz), 65W Intel® Core™ i7-6700TE Processor, Quad Core, 8M Cache, 2.4GHz (3.4GHz), 35W Intel® Core™ i5-6500 Processor, Quad Core, 6M Cache, 3.2GHz (3.6GHz), 65W Intel® Core™ i5-6500TE Processor, Quad Core, 6M Cache, 2.3GHz (3.3GHz), 35W Intel® Core™ i3-6100 Processor, Dual Core, 3M Cache, 3.7GHz, 47W Intel® Core™ i3-6100TE Processor, Dual Core, 4M Cache, 2.7GHz, 35W Intel® Pentium® Processor G4400, Dual Core, 3M Cache, 3.3GHz, 47W Intel® Pentium® Processor G4400TE, Dual Core, 3M Cache, 2.4GHz, 35W	
	Chipset	Intel® Q170	
	Memory	Four 288-pin DIMM up to 64GB	Dual Channel DDR4 1866/2133MHz
	BIOS	Insyde SPI 128Mbit	
GRAPHICS	Controller	Intel® HD Gen 9 Graphics	
	Feature	OpenGL 5.0, DirectX 12, OpenCL 2.1 HW Decode: AVC/H.264, MPEG2, VC1/WMV9, JPEG/MJPEG, HEVC/H265, VP8, VP9 HW Encode: MPEG2, AVC/H264, JPEG, HEVC/H265, VP8, VP9	
	Display	1 x VGA 1 x DVI (DVI-D signal) 1 x HDMI	VGA: resolution up to 1920x1200 @ 60Hz DVI: resolution up to 1920x1200 @ 60Hz HDMI: resolution up to 4096x2160 @ 24Hz
	Triple Displays	VGA + DVI (DVI-D signal) + HDMI	
EXPANSION	Interface	2 x PCIe x16 (1 x16 or 2 x8 signal) (Gen 3) 2 x PCIe x4 (Gen 3) 3 x PCI	
AUDIO	Audio Codec	Realtek ALC888S-VD2-GR	
ETHERNET	Controller	1 x Intel® I210AT PCIe (10/100/1000Mbps) 1 x Intel® I219LM PCIe with iAMT11.0 (10/100/1000Mbps) (only Core i7/i5 supports iAMT)	
REAR I/O	Ethernet	2 x GbE (RJ-45)	
	USB	4 x USB 3.0 2 x USB 2.0	
	Serial	1 x RS-232/422/485 (RS-232 w/ power) (DB-9)	
	PS/2	1 x PS/2 (mini-DIN-6)	
	Display	1 x VGA 1 x DVI (DVI-D signal) 1 x HDMI	
	Audio	1 x Line-in (available upon request) 1 x Line-out 1 x Mic-in	
	INTERNAL I/O	Serial	1 x RS-232/422/485 (RS-232 w/ power) (2.54mm pitch) 4 x RS-232 (2.54mm pitch)
USB		2 x USB 3.0 (2.00mm pitch) 6 x USB 2.0 (2.54mm pitch) or 4 x USB 2.0 (2.54mm pitch) + 1 x Vertical USB 2.0 (type A) (available upon request)	
Audio		1 x Audio (Line-out/Mic-in) 1 x S/PDIF	
SATA		6 x SATA 3.0 (up to 6Gb/s)	RAID 0/1/5/10
DIO		1 x 8-bit DIO	
LPC		1 x LPC (supports LPC EXT-RS232/RS485 module)	
SMBus		1 x SMBus	
WATCHDOG TIMER		Output & Interval	System Reset, Programmable via Software from 1 to 255 Seconds
SECURITY	TPM	Available Upon Request	
POWER	Type	ATX	
	Connector	8-pin ATX 12V power	24-pin ATX power
	Consumption	TBD	
	RTC Battery	CR2032 Coin Cell	
OS SUPPORT		Windows 7 (32/64-bit) Windows 10 Enterprise (64-bit)	Windows 8.1 (64-bit)
ENVIRONMENT	Temperature	Operating: 0 to 60°C	Storage: -40 to 85°C
	Humidity	Operating: 5 to 90% RH	Storage: 5 to 90% RH
MECHANICAL	Dimensions	ATX Form Factor	305mm (12") x 244mm (9.6")
	Height	PCB: TBD	Top Side: TBD, Bottom Side: TBD

Ordering Information

Model Name	P/N	Memory	GbE	RS-232/422/485	RS-232	USB 3.0	USB 2.0	Power	Thermal	Temp.
SD631-Q170CRM	770-SD6311-000G	4 DIMM	2	2	4	6	8	24-pin ATX	Active	0 to 60°C

Packing List

• 1 SD631-Q170 motherboard	
• 1 COM port cables (Length: 400mm)	A81-015012-001G
• 1 Serial ATA data cable (Length: 500mm)	332-553001-005G
• 1 I/O shield	A49-SD6300-000G
• 1 DVD	
• 1 QR (Quick Reference)	

Optional Items

• USB 2.0 port cable (Length: 350/398mm)	332-253010-026G
• USB 3.0 port cable (Length: 200mm)	TBD
• COM port cable (Length: 400mm)	A81-015012-001G
• Serial ATA data cable (Length: 500mm)	332-553001-005G
• Thermal solution (For 35W, Height: 37.3mm)	A71-103004-000G
• Thermal solution (For 65W, Height: 72.8mm)	552-200049-000G
• LPC EXT-RS232 module (4 x RS232 ports)	770-EXTRS1-000G
• LPC EXT-RS485 module (4 x RS485 ports)	770-EXTRS1-100G