

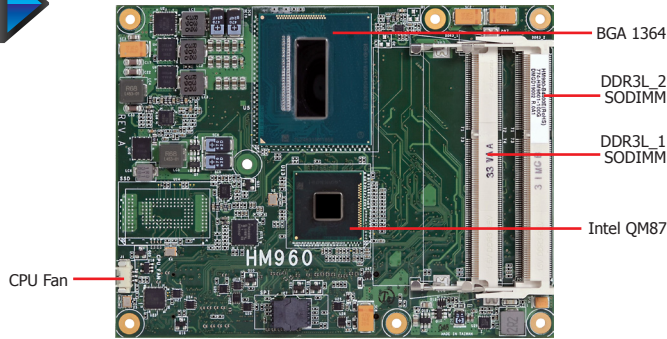

HM960-QM87

QM87



Features

| | |
|------------|--|
| MEMORY | 2 DDR3L SODIMM up to 16GB |
| EXPANSION | 1 PCIe x16, 7 PCIe x1 1 LPC, 1 I ² C, 1 SMBus, 2 serial 1 VGA, 1 LVDS, 3 DDI (HDMI/DVI/DP) 12 USB: 4 USB 3.0, 8 USB 2.0 4 SATA 3.0 SSD (optional) 4-bit input and 4-bit output GPIO |
| LAN | 1 LAN |
| DIMENSIONS | COM Express® R2.1 Basic, Type 6 95mm x 125mm (3.74" x 4.9") |



Mechanical Drawing

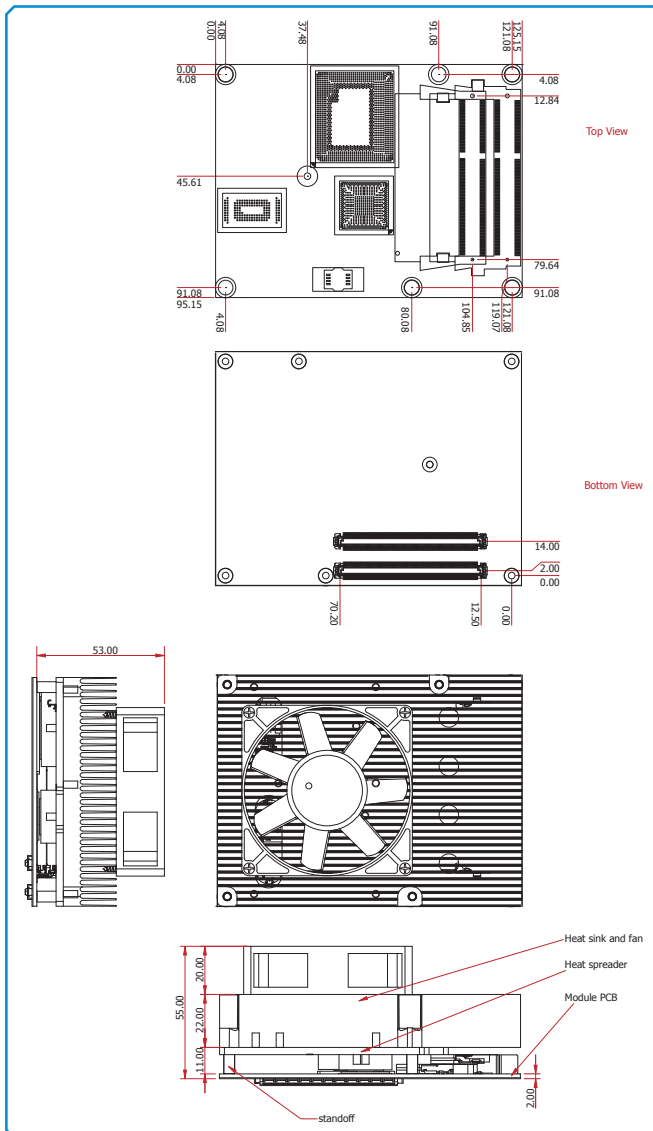

Block Diagram

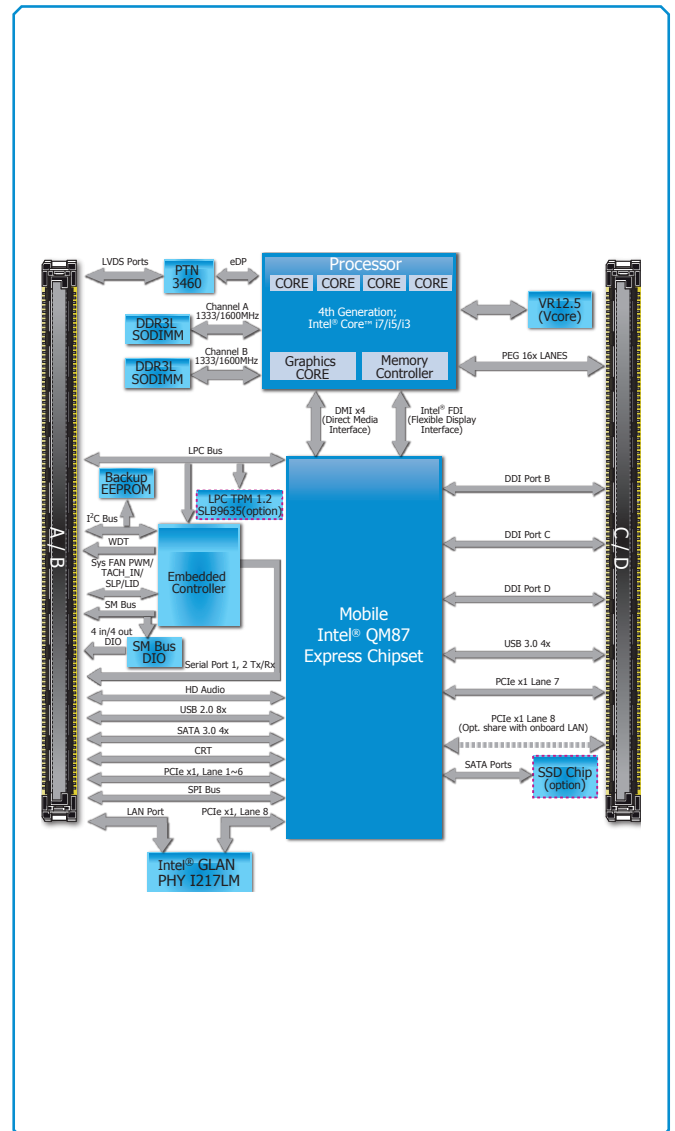

HM960-QM87

► Specifications * Optional and is not supported in standard model. Please contact your sales representative for more information.

PROCESSOR

- 4th generation Intel® Core™ processors
- BGA 1364 packaging technology
- 22nm process technology
- Please refer to the *Ordering Information* below

CHIPSET

- Intel® QM87 Express Chipset

SYSTEM MEMORY

- Two 204-pin DDR3L SODIMM sockets
- Supports DDR3L 1333/1600MHz SODIMM
- Supports up to 16GB system memory
- DRAM device technologies: 1Gb, 2Gb and 4Gb DDR3L DRAM technologies are supported for x8 and x16 devices, unbuffered, non-ECC

ONBOARD GRAPHICS FEATURES

- Intel® HD Graphics 4600
- Supports 1 VGA, 1 LVDS and 3 DDI
- VGA: resolution up to 2048x1536 @ 75Hz
- LVDS: NXP PTN3460, 24-bit, dual channel, resolution up to 1920x1200 @ 60Hz
- Digital Display Interface: HDMI, DVI and DP
- HDMI: resolution up to 4096x2304 @ 24Hz or 2560x1600 @ 60Hz
- DVI: resolution up to 1920x1200 @ 60Hz
- DP: resolution up to 3840x2160 @ 60Hz
- Intel® Clear Video Technology
- Intel® Advanced Vector Extensions (Intel® AVX) Instructions
- Supports DirectX 11.1, OpenGL 4.0, OpenCL 1.2

ONBOARD AUDIO FEATURES

- Supports High Definition Audio interface

ONBOARD LAN FEATURES

- Intel® I217LM with iAMT9.0 Gigabit Ethernet Phy
- Integrated 10/100/1000 transceiver
- Fully compliant with IEEE 802.3, IEEE 802.3u, IEEE 802.3ab

SERIAL ATA (SATA) INTERFACE

- Supports 4 SATA 3.0 with data transfer rate up to 6Gb/s
- Integrated Advanced Host Controller Interface (AHCI) controller
- Supports RAID 0/1/5/10
- Supports Intel® Smart Response Technology

USB INTERFACE

- XHCI Host Controller supports up to 4 super speed USB 3.0 ports

SSD*

- 2GB/4GB/8GB/16GB/32GB/64GB
- Write: 30MB/sec (max), Read: 70MB/sec (max)
- SATA to SSD onboard

INTEL ACTIVE MANAGEMENT TECHNOLOGY (AMT)

- Supports iAMT9.0
- Out-of-band system access
- Remote troubleshooting and recovery
- Hardware-based agent presence checking
- Proactive alerting
- Remote hardware and software asset tracking

TRUSTED PLATFORM MODULE (TPM)*

- Provides a Trusted PC for secure transactions
- Provides software license protection, enforcement and password protection

EXPANSION INTERFACES

- Supports 4 USB 3.0 interfaces
- Supports 8 USB 2.0 interfaces
- Supports 1 PCIe x16 Gen 3 interface
- Supports 7 PCIe x1 interfaces
- Supports LPC interface
- Supports SMBus interface
- Supports I²C interface
- Supports 2 serial interfaces (TX/RX)
- Supports 4-bit input and 4-bit output GPIO

DAMAGE FREE INTELLIGENCE

- Monitors CPU temperature and overheat alarm
- Monitors CPU fan speed and failure alarm
- Monitors Vcore/1.05V/DDR voltages and failure alarm

BIOS

- AMI BIOS
- 64Mbit SPI BIOS

WATCHDOG TIMER

- Software programmable from 1 to 255 seconds

POWER

- Input: 12V, VCC_RTC, 5VSB*

POWER CONSUMPTION

- TBD

OS SUPPORT

- Windows XP Professional x86 & SP3 (32-bit) (limited function)
- Windows 7 Ultimate x86 & SP1 (32-bit)
- Windows 7 Ultimate x64 & SP1 (64-bit)
- Windows 8 Enterprise x86 (32-bit)
- Windows 8 Enterprise x64 (64-bit)

TEMPERATURE

- Operating: 0°C to 60°C
- Storage: -20°C to 85°C

HUMIDITY

- 5% to 90%

MTBF

- 688,851 hrs @ 25°C; 397,149 hrs @ 45°C
- Calculation model: Telcordia Issue 2, Method I Case 3
- Environment: GB, GC – Ground Benign, Controlled

PCB

- Dimensions
 - COM Express® Basic
 - 95mm (3.74") x 125mm (4.9")
- Compliance
 - PICMG COM Express® R2.1, Type 6

CERTIFICATION

- CE, FCC Class B, RoHS

► Ordering Information

| Model Name | Processor | Memory | SSD | Power | Thermal | Temperature |
|----------------------|--|----------|------|--------|---------|-------------|
| HM960-QM87BS0-4700EQ | Intel® Core™ i7-4700EQ, 6M Cache, 2.4GHz (3.4GHz), 47W | 2 SODIMM | None | ATX/AT | Cooler | 0°C to 60°C |
| HM960-QM87BS0-4400E | Intel® Core™ i5-4400E, 3M Cache, 2.7GHz (3.3GHz), 37W | 2 SODIMM | None | ATX/AT | Cooler | 0°C to 60°C |

► Packing List

- 1 HM960 board
- 1 QR (Quick Reference)
- 1 DVD
- Heat spreader with heat sink and fan: 761-HSWMBL-000G

► Optional Items

- COM331-B carrier board kit: 770-COM331-000G
- Heat spreader: A71-011029-000G