

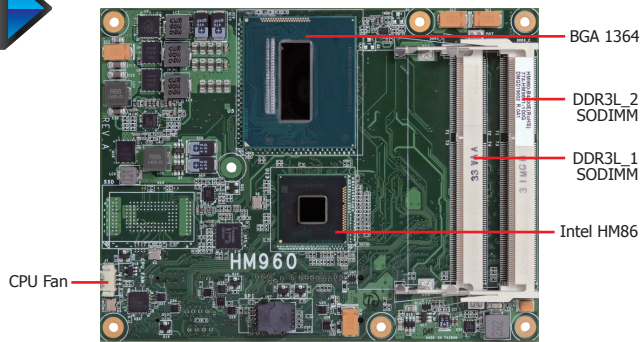

HM960-HM86

HM86



Features

MEMORY	2 DDR3L SODIMM up to 16GB
EXPANSION	1 PCIe x16, 7 PCIe x1 1 LPC, 1 SMBus, 1 I ² C, 2 serial 1 VGA, 1 LVDS, 3 DDI (HDMI/DVI/DP) 2 USB 3.0, 8 USB 2.0 4 SATA: 2 SATA 3.0, 2 SATA 2.0 SSD (optional) 4-bit input and 4-bit output GPIO
LAN	1 LAN
DIMENSIONS	COM Express® R2.1 Basic, Type 6 95mm x 125mm (3.74" x 4.9")



Mechanical Drawing

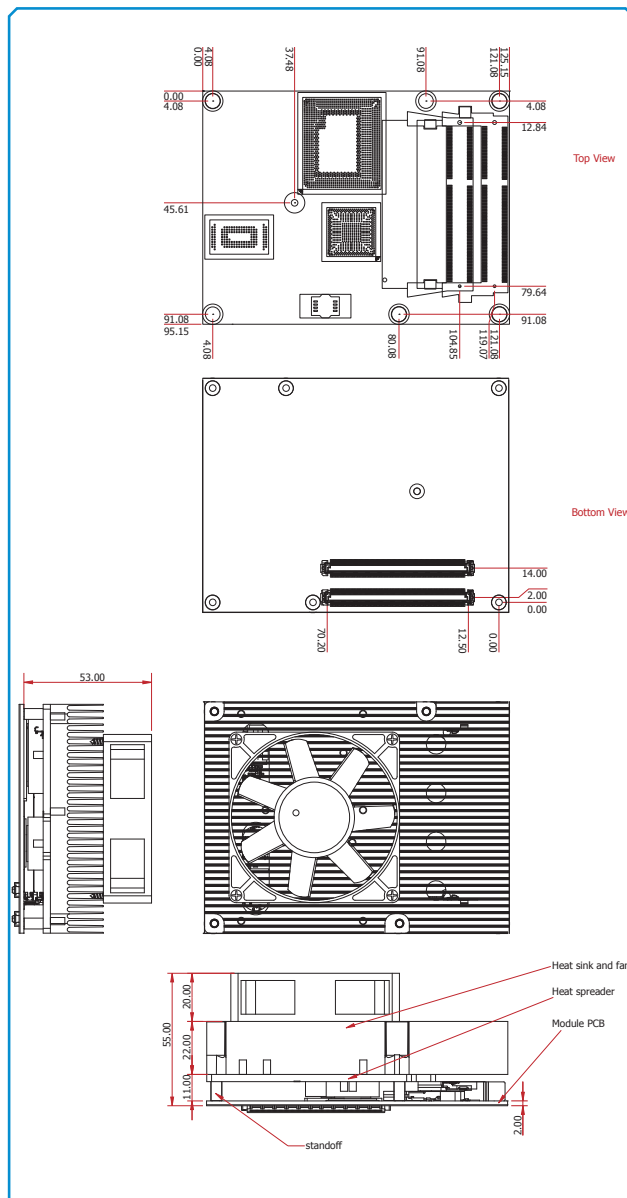

Block Diagram

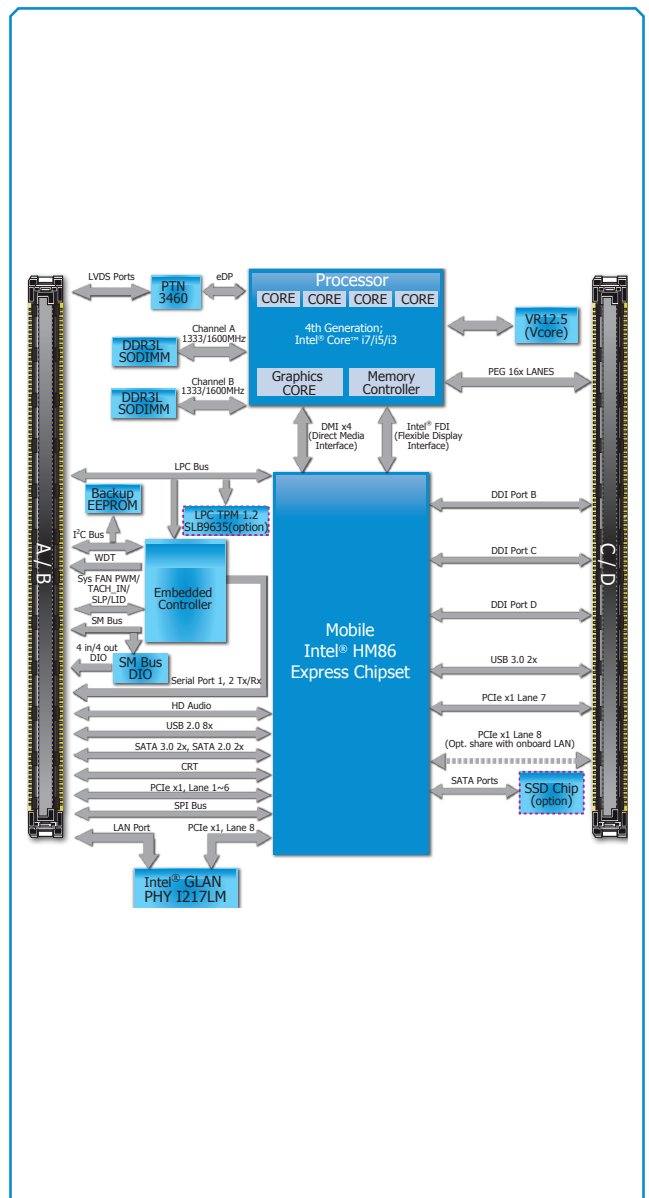

HM960-HM86

► Specifications

PROCESSOR

- 4th generation Intel® Core™ processors
- BGA 1364 packaging technology
- 22nm process technology
- Please refer to the Ordering Information below

CHIPSET

- Intel® HM86 Express Chipset

SYSTEM MEMORY

- Two 204-pin DDR3L SODIMM sockets
- Supports DDR3L 1333/1600MHz SODIMM
- Supports up to 16GB system memory
- DRAM device technologies: 1Gb, 2Gb and 4Gb DDR3L DRAM technologies are supported for x8 and x16 devices, unbuffered, non-ECC

ONBOARD GRAPHICS FEATURES

- Intel® HD Graphics 4600
- Supports 1 VGA, 1 LVDS and 3 DDI
- VGA: resolution up to 2048x1536 @ 75Hz
- LVDS: NXP PTN3460, 24-bit, dual channel, resolution up to 1920x1200 @ 60Hz
- Digital Display Interface: HDMI, DVI and DP
- HDMI: resolution up to 4096x2304 @ 24Hz or 2560x1600 @ 60Hz
- DVI: resolution up to 1920x1200 @ 60Hz
- DP: resolution up to 3840x2160 @ 60Hz
- Intel® Clear Video Technology
- Intel® Advanced Vector Extensions (Intel® AVX) Instructions
- Supports DirectX 11.1, OpenGL 3.2, OpenCL 1.2

ONBOARD AUDIO FEATURES

- Supports High Definition Audio interface

ONBOARD LAN FEATURES

- Intel® I217LM Gigabit Ethernet Phy
- Integrated 10/100/1000 transceiver
- Fully compliant with IEEE 802.3, IEEE 802.3u, IEEE 802.3ab

SERIAL ATA (SATA) INTERFACE

- Supports 2 SATA 3.0, and 2 SATA 2.0
- Supports 2 SATA 3.0, 1 SATA 2.0, and 1 SSD (optional)
- Integrated Advanced Host Controller Interface (AHCI) controller

USB INTERFACE

- XHCI Host Controller supports up to 2 super speed USB 3.0 ports

SSD - optional

- 2GB/4GB/8GB/16GB/32GB/64GB
- Write: 30MB/sec (max), Read: 70MB/sec (max)
- SATA to SSD onboard

TRUSTED PLATFORM MODULE (TPM) - optional

- Provides a Trusted PC for secure transactions
- Provides software license protection, enforcement and password protection

EXPANSION INTERFACES

- Supports 2 USB 3.0 interfaces
- Supports 8 USB 2.0 interfaces
- Supports 1 PCIe x16 Gen 3 interface
- Supports 7 PCIe x1 interfaces
- Supports LPC interface
- Supports SMBus interface
- Supports I²C interface
- Supports 2 serial interfaces (TX/RX)
- Supports 4-bit input and 4-bit output GPIO

DAMAGE FREE INTELLIGENCE

- Monitors CPU temperature and overheat alarm
- Monitors CPU fan speed and failure alarm
- Monitors Vcore/1.05V/DDR voltages and failure alarm

BIOS

- AMI BIOS
- 64Mbit SPI BIOS

WATCHDOG TIMER

- Software programmable from 1 to 255 seconds

POWER

- Input: 12V, VCC_RTC, 5VSB (option)

POWER CONSUMPTION

- TBD

OS SUPPORT

- Windows 8 Enterprise x86 (32-bit)
- Windows 8 Enterprise x64 (64-bit)
- Windows 7 Ultimate x86 & SP1 (32-bit)
- Windows 7 Ultimate x64 & SP1 (64-bit)
- Windows XP Professional x86 & SP3 (32-bit)
- Windows XP Professional x64 & SP2 (64-bit)
- (based on Intel's Windows XP support list)

TEMPERATURE

- Operating: 0°C to 60°C
- Storage: -20°C to 85°C

HUMIDITY

- 5% to 90%

PCB

- Dimensions
 - COM Express® Basic
 - 95mm (3.74") x 125mm (4.9")
- Compliance
 - PICMG COM Express® R2.1, Type 6

► Ordering Information

Model Name	Chipset	Temperature	Memory	SSD	Processors
HM960	- HM86	B	S	0	- 4700EQ
		B: 0°C to 60°C	S: Socket	0: None 2: 2GB 4: 4GB 8: 8GB 1: 16GB 3: 32GB 6: 64GB	4700EQ: Intel® Core™ i7-4700EQ, 6M Cache, up to 3.4 GHz, 47W 4400E: Intel® Core™ i5-4400E, 3M Cache, up to 3.3 GHz, 37W 4402E: Intel® Core™ i5-4402E, 3M Cache, up to 2.7 GHz, 25W 4100E: Intel® Core™ i3-4100E, 3M Cache, 2.4 GHz, 37W 4102E: Intel® Core™ i3-4102E, 3M Cache, 1.6 GHz, 25W 2000E: Intel® Celeron® 2000E, 2M Cache, 2.2 GHz, 37W 2002E: Intel® Celeron® 2002E, 2M Cache, 1.5 GHz, 25W

► Packing List

- 1 HM960 board
- 1 QR (Quick Reference)
- 1 DVD

► Optional Items

- COM331-B carrier board kit
- COM101-BAT carrier board kit
- Heat spreader with heat sink and fan: 761-HSWMBL-000G